









# FL SERIES SPECIFICATION

MACHINE TYPE [FL]	330	440	660
Theoretical maximum yield [kg/h]	1500	4000	8000
Cutting dimension [mm]	250x420x650	250x420x650	350x810x650
Cutting thickness	low knives - 3,6,9 mm high knives - 14,17,20 mm	low knives - 3,6,9 mm high knives - 14,17,20 mm	low knives - 3,6,9 mm high knives - 14,17,20 mm
Amount of cutting blades	4 pcs (high knives in set)	4 pcs (high knives in set)	7 pcs (high knives in set)
Speed cutting drum [rpm]	130	I-70 II-140	112
Motor power [kW]	7,5	9,2/11,5	18,5
Standard voltage	400,50	400,50	400,50
Standard control			
Flaker net weight [kg]	590	980	1860
Fuse [A]	20	32	50
Loader option	-	PZ 3/250	PZ 3/250
Cutting to	<b>200L</b> 	<b>200L</b> 	<b>BIG BOX</b> 
Opening/ Closing lids			
Required pressure [bar]	-	6	6
Block temperature	-30°C	-30°C	-30°C

MODEL OF MACHINES [FL]	330	440	660
Loader option	-	o	o
Button control panel	S	S	S

# FL SERIES SPECIFICATION

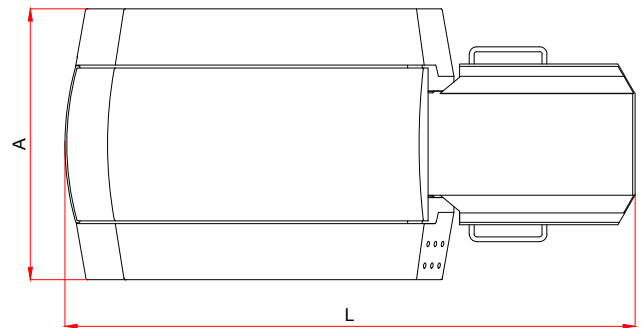
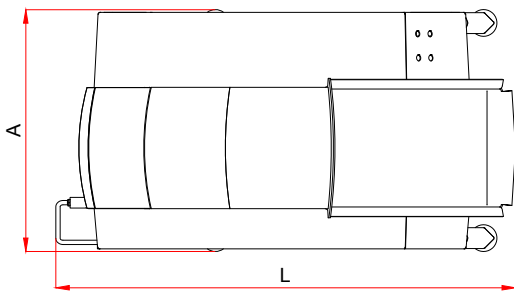
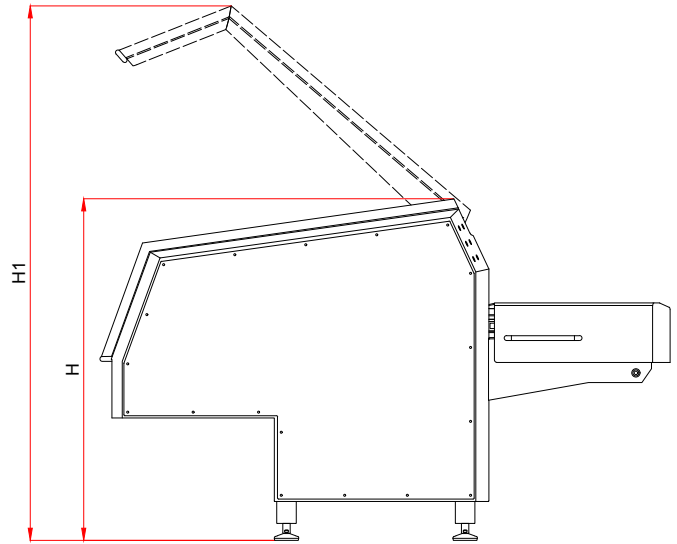
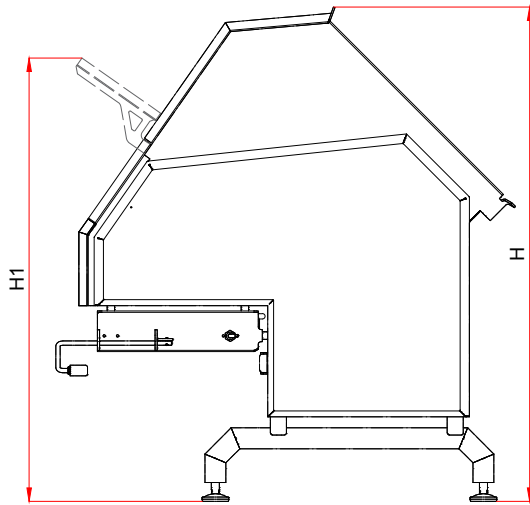

**FL 330**

**FL 440 & FL 660**

MODEL OF MACHINES [FL]	330	440	660
H [cm]	185	141	178
H1 [cm]	166	211	269
L [cm]	172	236	295
A [cm]	90	112	160