















# SPECYFIKACJA URZĄDZEŃ SERII MIX Z & MIX ZV

TYP MASZINY [MIX]	300 Z	500 Z	1000 Z	1500 Z	2600 Z
	300 ZV	500 ZV	1000 ZV	1500 ZV	2600 ZV
Pojemność całkowita [L]	300	500	1000	1500	2600
Maksymalny wsad [L]	180	300	600	900	1560
Moc zainstalowana [kW]	7,5	11	22	30	55
Prędkość obrotowa wałów [rpm]	5-48	4-40	4-30	3-28	3-26
Sterowanie standardowe					
Masa maszyny netto [kg]	1100	1420	2850	4050	6050
	1180	1550	3020	4250	6300
BUSCH pompa próżniowa [m <sup>3</sup> /h]	-	-	-	-	-
	21	21	40	63	100
Zabezpieczenie prądowe	32	50	100	120	160
Opcje załadunku	PW 2/250	PW 2/250	PW 2/250	PW 2/250	PW 2/250
Wyładunek	<b>200L</b> 	<b>2x200L</b> 	<b>2x200L</b> 	<b>2x200L</b> 	<b>2x200L</b> 
Otwieranie/ Zamykanie pokryw					

MODEL MASZINY [MIX]	300 Z	500 Z	1000 Z	1500 Z	2600 Z
	300 ZV	500 ZV	1000 ZV	1500 ZV	2600 ZV
Podajnik załadunkowy	o	o	o	o	o
PLC i HMI	S	S	S	S	S
Płynna regulacja obrotów	S	S	S	S	S
Pomiar temperatury farszu	o	o	o	o	o
Automatyczne dozowanie wody	o	o	o	o	o
System wagowy	o	o	o	o	o
System uszczelnień "Eeasy Clean"	o	o	o	-	-
	-	-	-	-	-
Dodatkowa ażurowa osłona górna	-	-	-	-	-
Szlifowana wanna i wały	S	S	S	S	S
Podwójny płaszcz max ciśnienie 2,0 Bar	o	o	o	o	o
Pełna, szczelna pokrywa	o	o	o	o	o
	S	S	S	S	S
Wały łopatkowe	o	o	o	o	o

# SPECYFIKACJA URZĄDZEŃ SERII MIX Z & MIX ZV

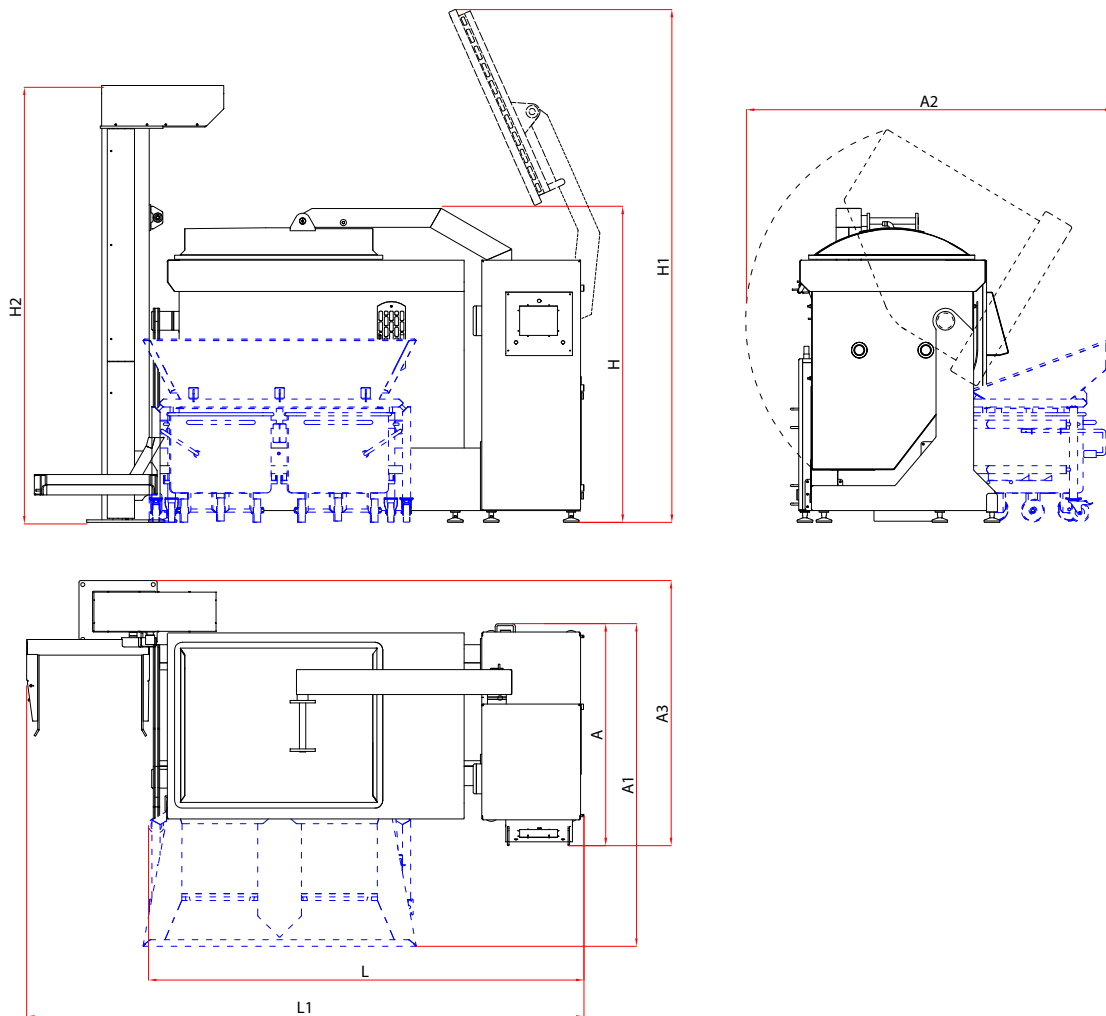

MODEL MASZINY [MIX]	300 Z	500 Z	1000 Z	1500 Z	2600 Z
	300 ZV	500 ZV	1000 ZV	1500 ZV	2600 ZV
H [cm]	163	192	201	228	296
H1 [cm]	140	154	170	195	244
H2 [cm]	260	290	328	378	462
H3 [cm]	255	271	282	300	361
L [cm]	203	216	278	327	399
L1 [cm]	283	295	358	407	475
A [cm]	98	110	142	167	212
A1 [cm]	160	178	206	222	270
A2 [cm]	182	202	234	253	309
A3 [cm]	133	145	176	201	230



RYSunEK TECHNICZNY I ZDJĘCIA MAJĄ WYŁĄCZNIE CHARAKTER POGŁĄDOWY I MOGĄ RÓŻNIĆ SIĘ OD RZECZYWISTEGO PRODUKTU.