







# MV SERIE SPEZIFIKATION

MASCHINENTYP [MV]	300	600	1000
Gesamtkapazität [L]	300	600	1000
Max füllung [L]	160	380	600
Motorleistung [kW]	2,3	4,0	7,0
Sicherung [A]	16	20	25
Beschickung option	PZ 3/250	HEBEARM	HEBEARM
Busch vakuumpumpe [m <sup>3</sup> /h]	21	40	40
Standardsteuerung			
Stufenlose Drehzahlregelung der Wellen [rpm]	0-9	0-9	0-9
Mischer Nettogewicht [kg]	160	380	1480
Entladen Standard-Füllwagen DIN9797	200L 	200L 	200L 

MODELL DER MASCHINEN [MV]	300	600	1000
Beschickung option	o	o	o
PLC und HMI	S	S	S
Glatte variable Geschwindigkeit	S	S	S
Temperatursensor	o	o	o
Wasserdosiersystem	-	-	-
Doppeljacke max. Druck 2,0 [bar]	-	-	-

# MV SERIE SPEZIFIKATION

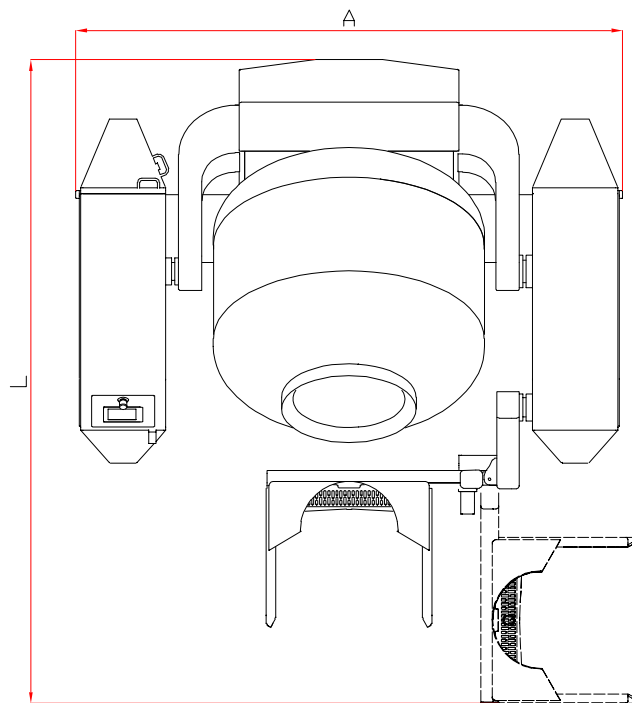
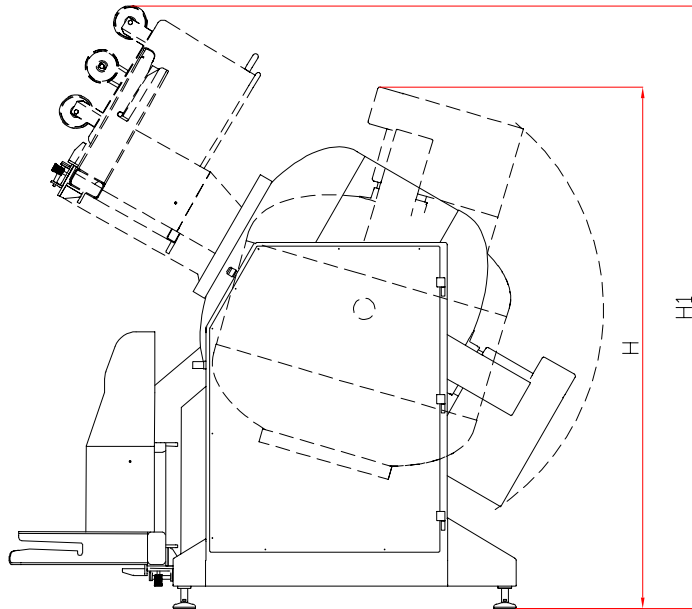

MODELL DER MASCHINEN [MV]	300	600	1000	600 mit HEBEARM	1000 mit HEBEARM
H [cm]	187	190	232	190	232
H1 [cm]	-	-	-	261	269
L [cm]	132	153	180	233	288
A [cm]	158	200	225	216	244