

P SERIE SPEZIFICATION

MAST-BESCHICKUNG [P]	PW 2/250 (freistehende Version)	PM 2/250 (bewegliche Version)	PW 2/600	PW 2/1000
Maximale Tragfähigkeit [kg]	380	380	600	1000
Motorleistung [kW]	0,75	0,75	1,5	2,2
Sicherung [A]	10	10	10	10
Hubgeschwindigkeit [m/s]	0,1	0,1	0,1	0,1
Entladehöhe	Tabellenzeile - H1	Tabellenzeile - H1	Tabellenzeile - H1	Tabellenzeile - H1
Nettogewicht [kg]	330 (Typ Höhe III)	380 (Typ Höhe III)	605 (Typ Höhe I)	1100 (Typ Höhe I)

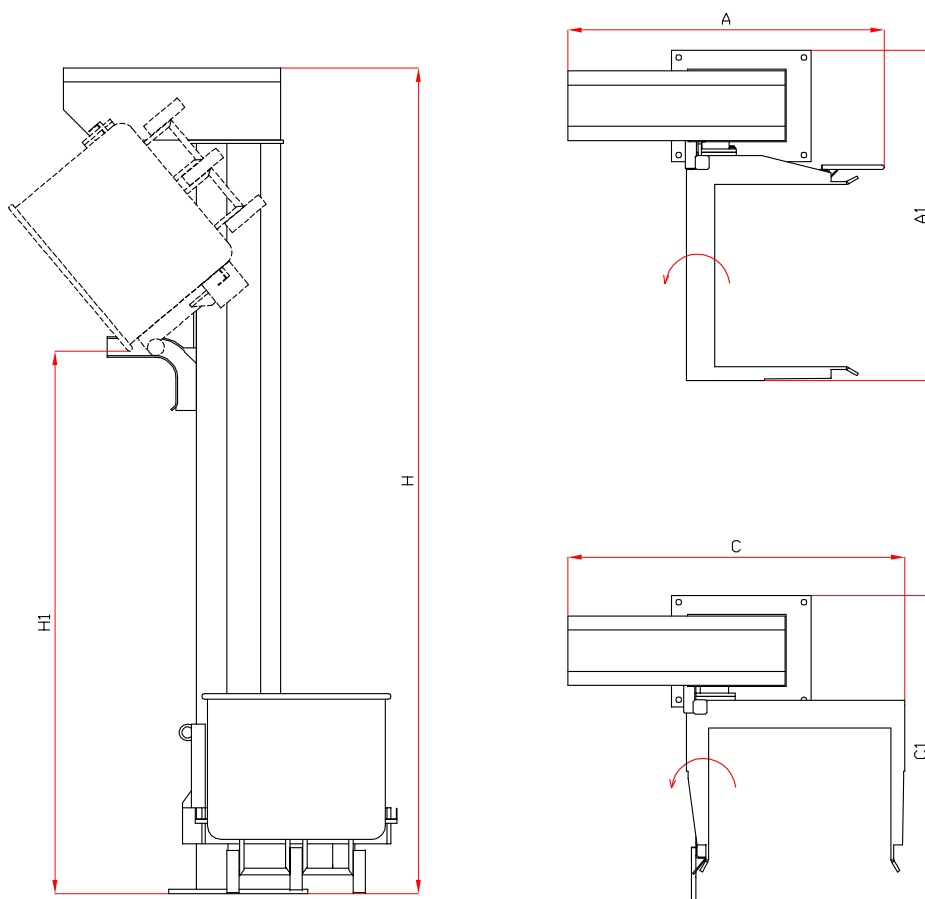

PW 2/250 (FREISTEHENDE VERSION)

TYP HÖHE	I	II	III	IV	V	VI	VII	VIII
H [cm]	249	279	297	322	338	358	378	406
H1 [cm]	105-155	135-185	155-205	175-225	195-245	215-265	235-285	265-315
A [cm]	114	114	114	114	114	114	114	114
A1 [cm]	119	119	119	119	119	119	119	119
C [cm]	121	121	121	121	121	121	121	121
C1 [cm]	112	112	112	112	112	112	112	112

P SERIE SPEZIFIKATION

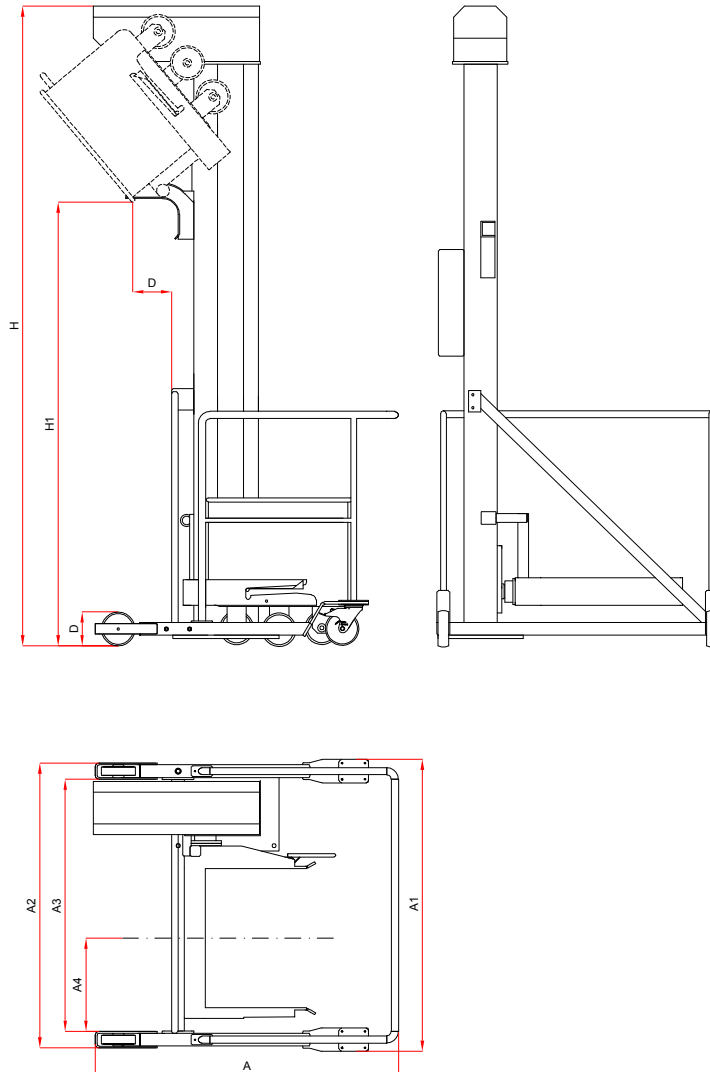

PM 2/250 (BEWEGLICHE VERSION)

TYP HÖHE	I	II	III	IV	V	VI
H [cm]	253	283	301	326	342	362
H1 [cm]	105-155	135-185	155-205	175-225	195-245	215-265
A [cm]	145	145	145	145	167	167
A1 [cm]	137	137	137	137	159	159
A2 [cm]	134	134	134	134	159	159
A3 [cm]	118	118	118	118	137	137
A4 [cm]	44	44	44	44	54	54
D [cm]	16	16	16	16	16	16

P SERIE SPEZIFIKATION

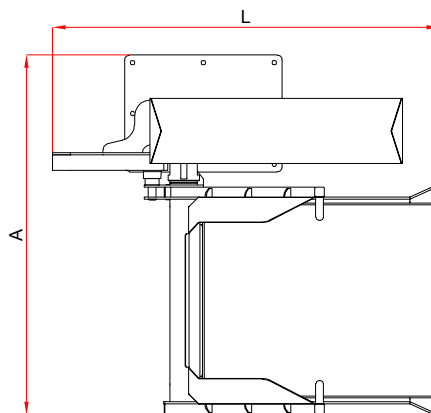
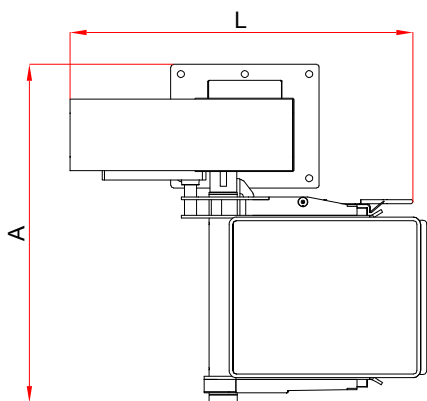
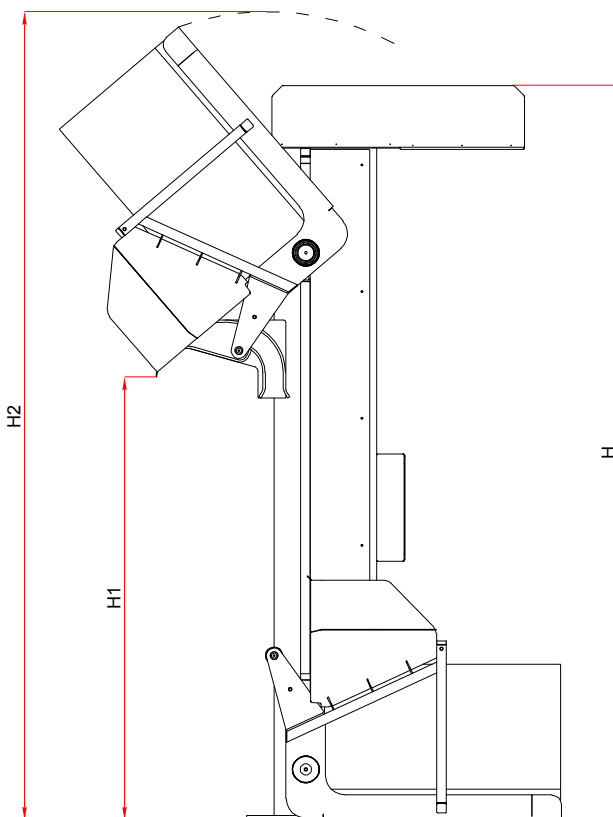
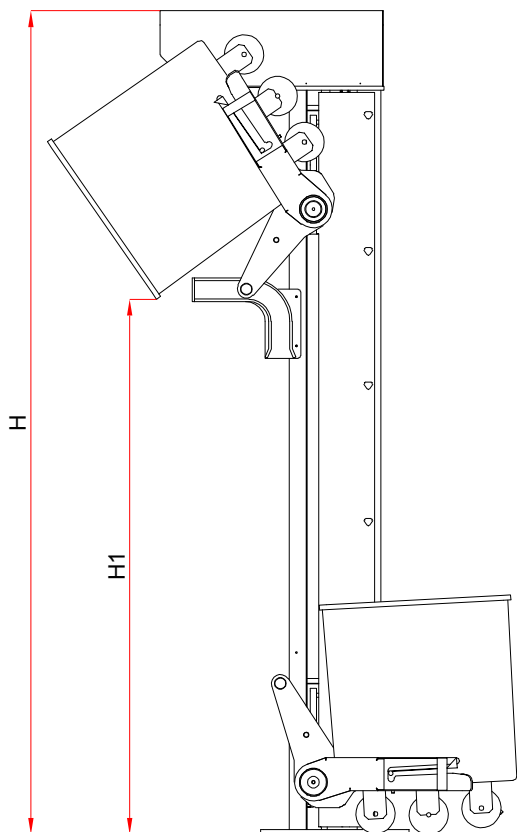

PW 2/600

PW 2/1000

TYP HÖHE	I	II	III
H [cm]	324	369	399
H1 [cm]	160-210	195-245	225-275
L [cm]	140	140	140
A [cm]	141	141	141

TYP HÖHE	I	II	III	IV	V	VI
H [cm]	286	335	377	401	431	453
H1 [cm]	66-136	115-185	157-227	181-251	211-281	233-303
H2 [cm]	325	374	416	440	470	492
L [cm]	197	197	197	197	197	197
A [cm]	186	186	186	186	186	186

P SERIE SPEZIFICATION

KIPPEINRICHTUGEN MODELL [P]	PZ 3/250	PZ 3/1000
Maximale Tragfähigkeit [kg]	380	1000
Mast-Beschickung power [kW]	0,75	1,5
Sicherung [A]	6	10
Spannung [V,Hz]	230,50 or 400,50	400,50
Nettogewicht [kg]	186	475 (Typ Höhe I)

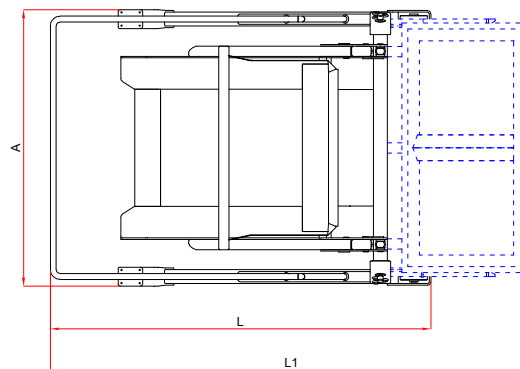
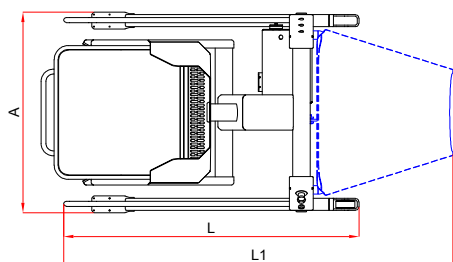
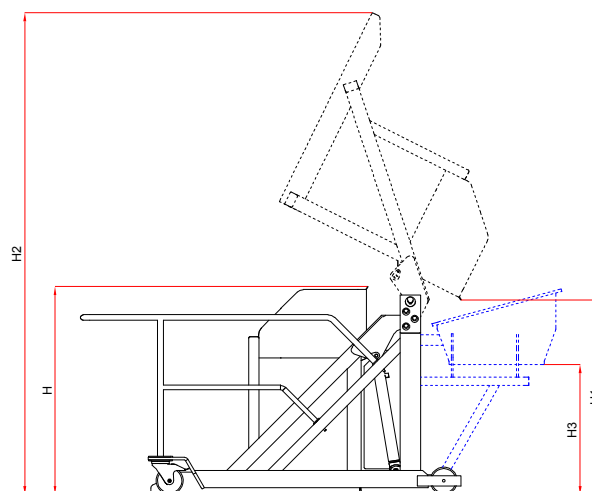
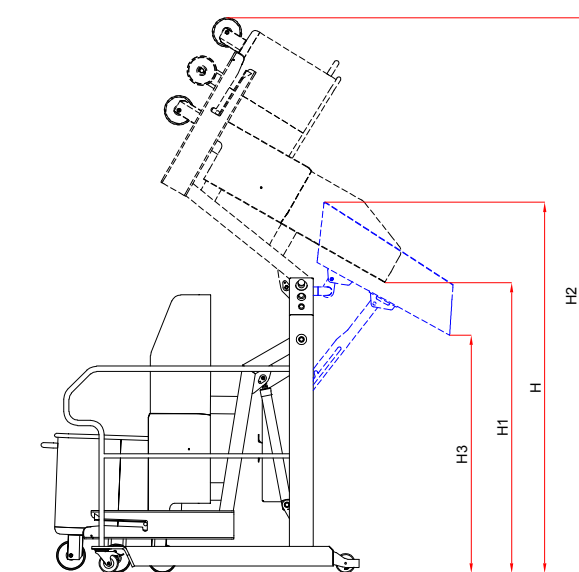

PZ 3/250

PZ 3/1000

TYP HÖHE	PZ 3/250	PZ 3/250 MV
H [cm]	129	189
H1 [cm]	118	148
H2 [cm]	240	283
H3 [cm]	-	110-133
L [cm]	130	151
L1 [cm]	-	198
A [cm]	103	103

TYP HÖHE	I	II	III
H [cm]	122	150	175
H1 [cm]	113	130	152
H2 [cm]	283	315	346
H3 [cm]	73	96	-
L [cm]	222	236	196
L1 [cm]	281	295	-
A [cm]	164	164	164