





MG SERIES SPECIFICATION

MACHINE TYPE [MG]	450/160	900/160	1500/200
Total capacity [L]	450	900	1500
Max filling [L]	338	675	1125
Mixer power [kW]	4,5	11	15
Grinder power [kW]	optionally	optionally	optionally
Shaft rotation speed [rpm]	20/40	16/32	14/28
Standard control			
Mixer net weight [kg]	1530	1970	2780
Diameter of throat [mm]	160	160	200
Fuse [A]	63/100	80/100	140/100
Opening/ Closing lids	 P	 P	 P
Required pressure [bar]	6	6	6

MODEL OF MACHINES [MG]	450/160	900/160	1500/200
Column loader	o	o	o
Button control panel	S	S	S
PLC and HMI	o	o	o
Smooth variable speed	o	o	o
Temperature sensor	o	o	o
Water dosing system	o	o	o
Weighing system	o	o	o
"Easy Clean" shafts seals	o	o	o
Additional grid	-	-	-
Polished shafts and bath	o	o	o
Double jacket max pressure 2,0 Bar	o	o	o
Dust proof sealed lid	o	o	o

MG SERIES SPECIFICATION

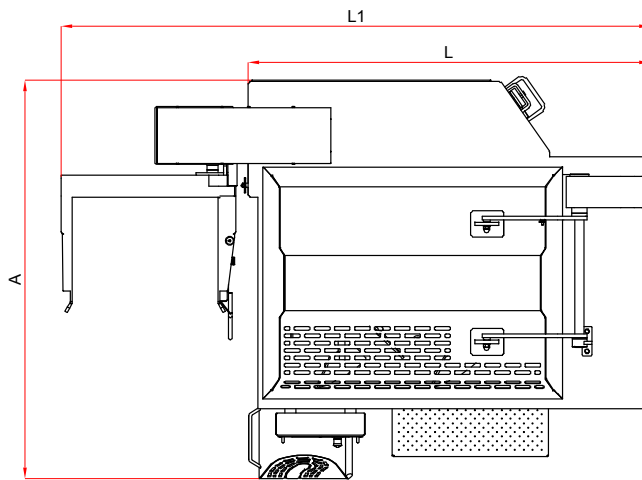
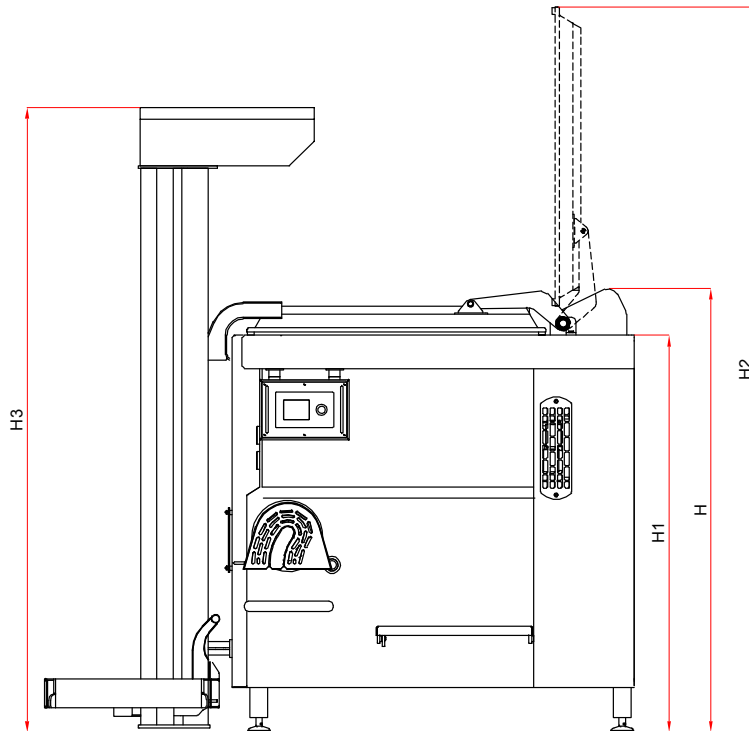

MODEL OF MACHINES [MG]	450/160	900/160	1500/200
H [cm]	180	200	229
H1 [cm]	162	178	207
H2 [cm]	289	326	328
H3 [cm]	271	282	325
L [cm]	150	181	222
L1 [cm]	234	265	306
A [cm]	179	180	246