

# P SERIES SPECIFICATION

COLUMN LOADER MODEL [P]	PW 2/250 (free standing version)	PM 2/250 (movable version)	PW 2/600	PW 2/1000
Maximum lifting capacity [kg]	380	380	600	1000
Motor power [kW]	0,75	0,75	1,5	2,2
Fuse [A]	10	10	10	10
Lifting speed [m/s]	0,1	0,1	0,1	0,1
Discharge height	table row - H1	table row - H1	table row - H1	table row - H1
Net weight [kg]	330 (type height III)	380 (type height III)	605 (type height I)	1100 (type height I)

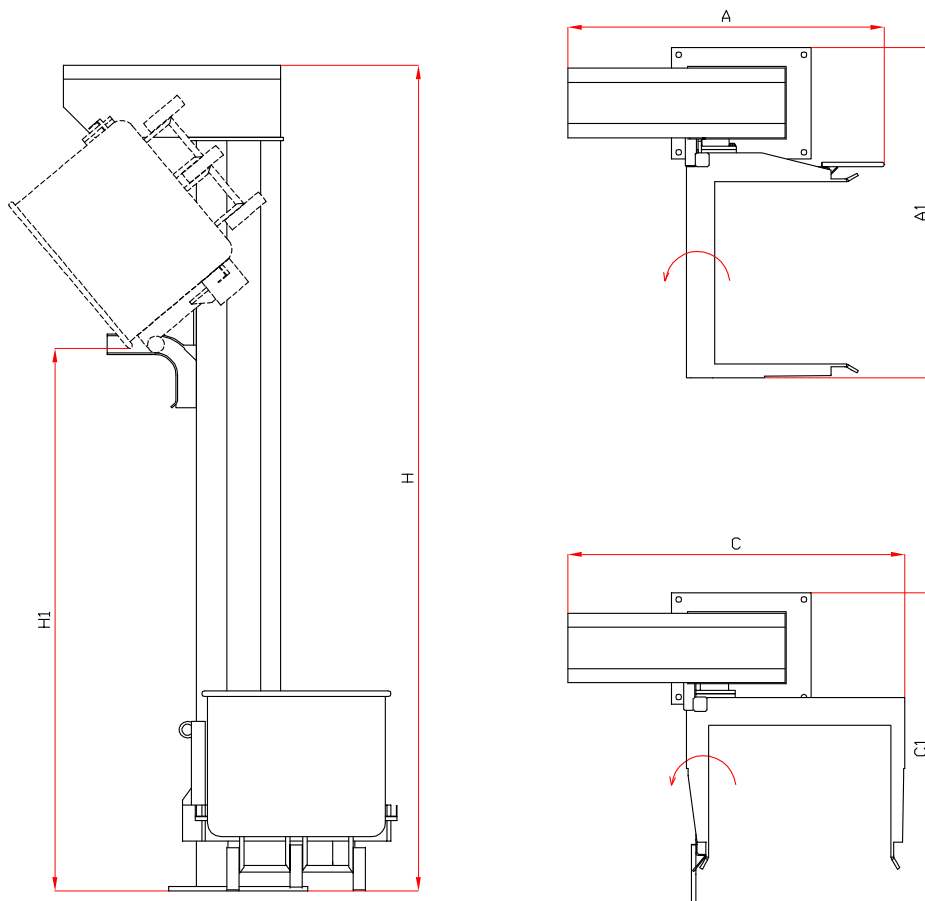

## PW 2/250 (FREE STANDING VERSION)

TYPE HEIGHT	I	II	III	IV	V	VI	VII	VIII
H [cm]	249	279	297	322	338	358	378	406
H1 [cm]	105-155	135-185	155-205	175-225	195-245	215-265	235-285	265-315
A [cm]	114	114	114	114	114	114	114	114
A1 [cm]	119	119	119	119	119	119	119	119
C [cm]	121	121	121	121	121	121	121	121
C1 [cm]	112	112	112	112	112	112	112	112

# P SERIES SPECIFICATION

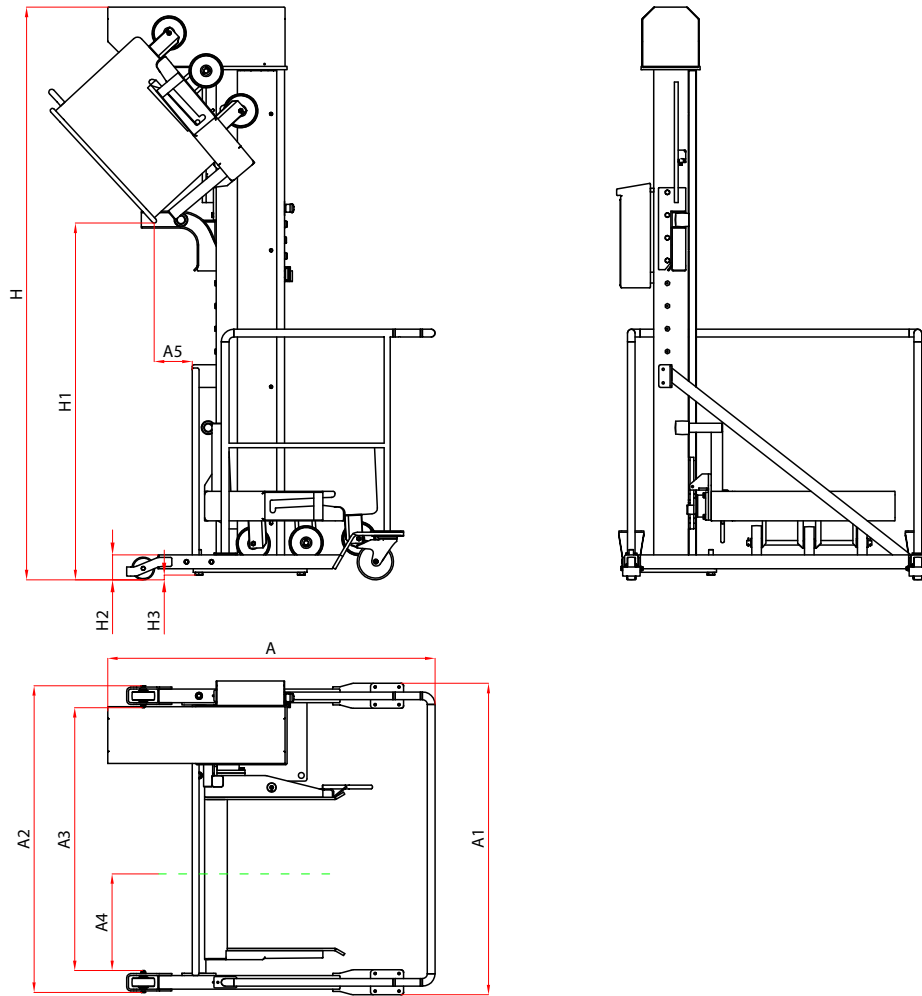

## PM 2/250 (MOVABLE VERSION)

TYPE HEIGHT	I	II	III	IV	V	VI	VII	VIII
H [cm]	253	283	301	326	342	362	382	410
H1 [cm]	105-155	135-185	155-205	175-225	195-245	215-265	235-285	265-315
H2 [cm]	11	11	11	11	11	11	11	11
H3 [cm]	2	2	2	2	2	2	2	2
A [cm]	144	144	144	144	162	162	162	162
A1 [cm]	137	137	137	137	159	159	159	159
A2 [cm]	135	135	135	135	157	157	157	157
A3 [cm]	116	116	116	116	137	137	137	137
A4 [cm]	43	43	43	43	53	53	53	53
A5 [cm]	16	16	16	16	13	13	13	13

# P SERIES SPECIFICATION

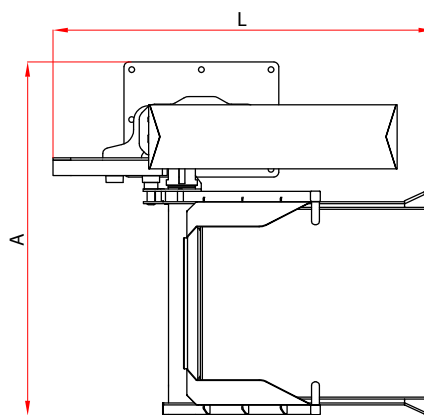
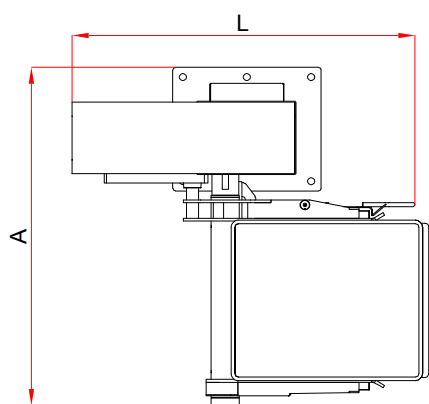
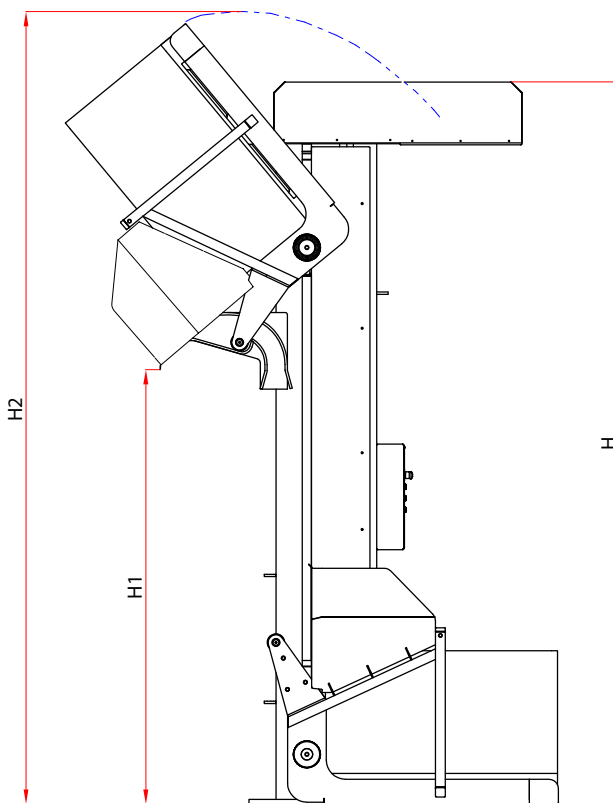
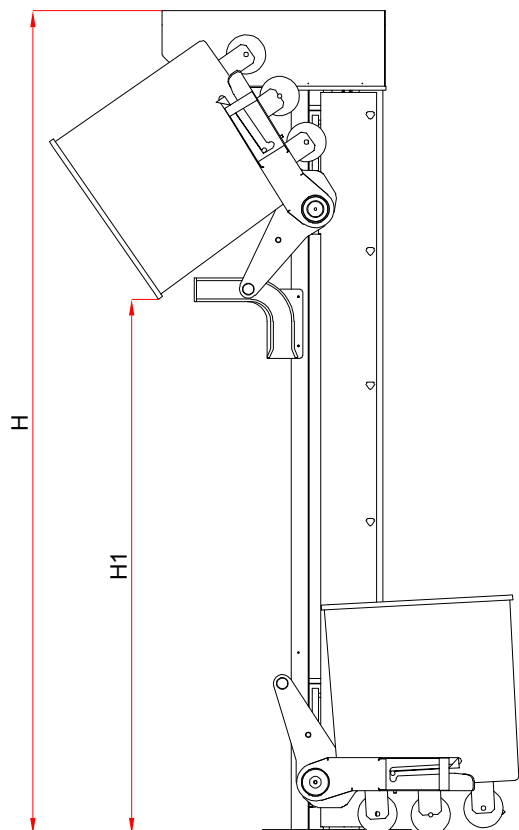

**PW 2/600**

**PW 2/1000**

TYPE HEIGHT	I	II	III
H [cm]	324	369	399
H1 [cm]	160-210	195-245	225-275
L [cm]	140	140	140
A [cm]	141	141	141

TYPE HEIGHT	I	II	III	IV	V	VI
H [cm]	286	335	377	401	431	453
H1 [cm]	100-135	149-184	191-226	215-250	228-280	250-302
H2 [cm]	325	374	416	440	470	492
L [cm]	197	197	197	197	197	197
A [cm]	186	186	186	186	186	186

# P SERIES SPECIFICATION

SWING LOADER MODEL [P]	PZ 3/250	PZ 3/1000
Maximum lifting capacity [kg]	380	1000
Column loader power [kW]	0,75	1,5
Fuse [A]	6	10
Voltage [V,Hz]	230,50 or 400,50	400,50
Net weight [kg]	186	475 (type height I)

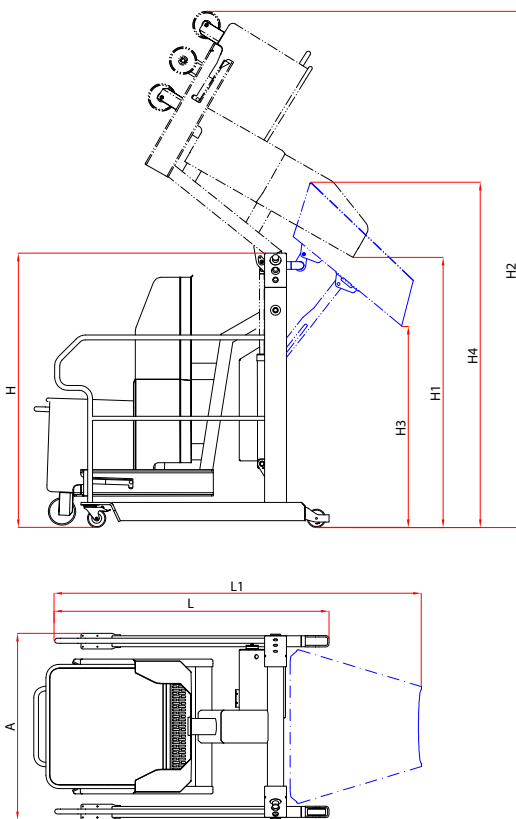

**PZ 3/250**

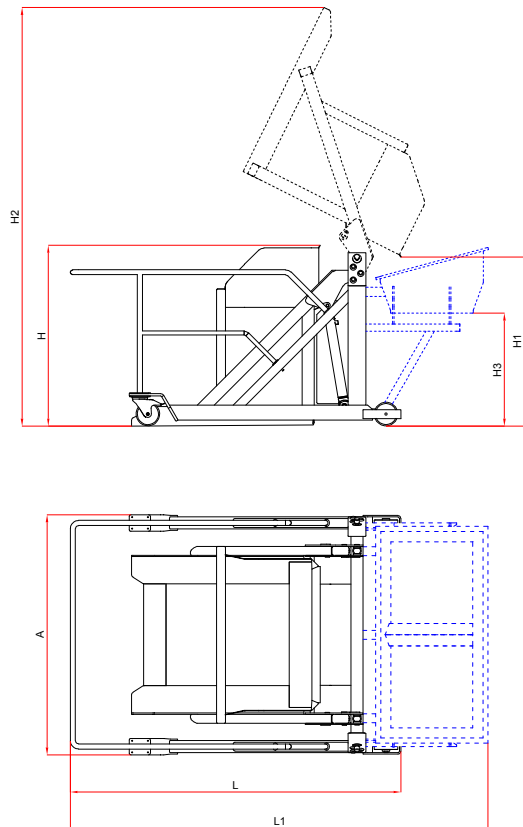

**PZ 3/1000**

TYPE HEIGHT	PZ 3/250	PZ 3/250 MV
H [cm]	129	150
H1 [cm]	118	148
H2 [cm]	240	283
H3 [cm]	-	110-133
H4 [cm]	-	189
L [cm]	130	151
L1 [cm]	-	198
A [cm]	103	103

TYPE HEIGHT	I	II	III
H [cm]	122	150	175
H1 [cm]	113	130	152
H2 [cm]	283	315	346
H3 [cm]	73	96	-
L [cm]	222	236	196
L1 [cm]	281	295	-
A [cm]	164	164	164