





LA SERIE MG ESPECIFICACIÓN

TIPO DE MÁQUINA [MG]	450/160	900/160	1500/200
Capacidad total [L]	450	900	1500
Llenado máximo [L]	338	675	1125
Potencia de la amasadora [kW]	4,5	11	15
Potencia de la picadora [kW]	opcionalmente	opcionalmente	opcionalmente
Velocidad de rotación del eje [rpm]	20/40	16/32	14/28
Manejo estándar			
Peso neto de la amasadora [kg]	1530	1970	2780
Boca de salida [mm]	160	160	200
Fuse [A]	63/100	80/100	140/100
Apertura/Cierre de tapa			
Presión requerida [bar]	6	6	6

MODELOS DE MAQUINAS [MG]	450/160	900/160	1500/200
Elevador de columna	o	o	o
Button control panel	S	S	S
PLC y HMI	o	o	o
Variación suave de velocidad	o	o	o
Sensor de temperatura	o	o	o
Sistema de dosificado de agua	o	o	o
Sistema de pesado	o	o	o
Juntas del eje de fácil limpieza	o	o	o
Rejilla adicional	-	-	-
Cuba y ejes pulidos	o	o	o
Doble camisa máx. presión 2.0 Bar	o	o	o
Cierre de tapa a prueba de partículas	o	o	o

LA SERIE **MG** ESPECIFICACIÓN

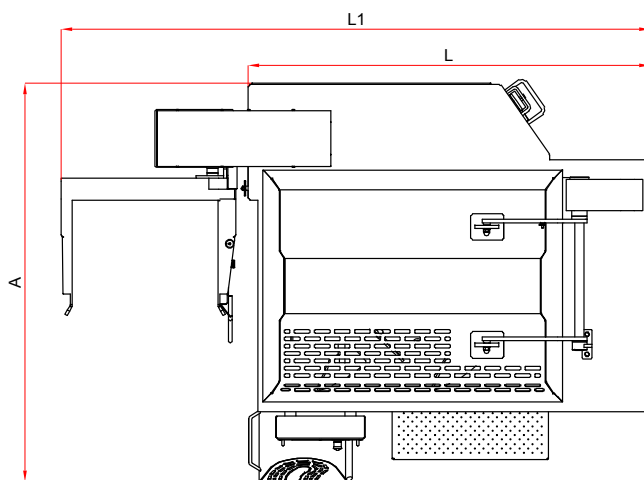
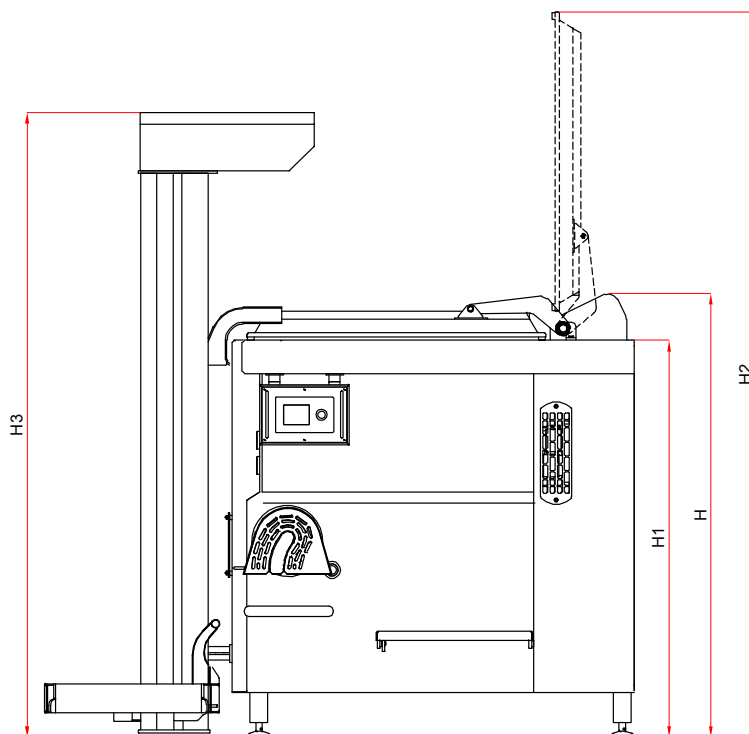

MODELOS DE MAQUINAS [MG]	450/160	900/160	1500/200
H [cm]	180	200	229
H1 [cm]	162	178	207
H2 [cm]	289	326	328
H3 [cm]	271	282	325
L [cm]	150	181	222
L1 [cm]	234	265	306
A [cm]	179	180	246