

SPECYFIKACJA URZĄDZEŃ SERII MIX S & MIX SV

TYP MASZYNY [MIX]	500 S	750 S	1000 S	1250 S	1600 S	2100 S	2600 S	3200 S	3800 S	4800 S
	500 SV	750 SV	1000 SV	1250 SV	1600 SV	2100 SV	2600 SV	3200 SV	3800 SV	4800 SV
Pojemność całkowita [L]	500	750	1000	1250	1600	2100	2600	3200	3800	4800
Maksymalny wsad [L]	375	563	750	938	1200	1575	1950	2400	2850	3600
Moc zainstalowana [kW]	2x3,0	2x5,5	2x5,5	2x5,5	2x7,5	2x11,0	2x11,0	2x15,0	2x15,0	2x22,0
Prędkość obrotowa wałów [rpm]	20/40	18/36	16/32	14/28	14/28	13/26	12/24	3-25	2-22	2-22
	5-40	4-36	4-32	4-30	3-28	3/28	3-25			
Sterowanie standardowe										
Masa maszyny netto [kg]	890	1100	1420	1982	2420	2840	3620	4380	4920	5420
	1020	1320	1620	2070	2820	3320	4170	5020	5890	6570
BUSCH pompa próżniowa [m³/h]	-	-	-	-	-	-	-	-	-	-
	21	40	40	40	63	100	100	160	160	200
Zabezpieczenie prądowe	25	32	32	32	40	63	63	100	100	120
Opcje załadunku	PZ 2/250	PZ 2/250	PZ 2/250 lub PW 2/1000	PZ 2/250 lub PW 2/1000	PZ 2/250 lub PW 2/1000	PZ 2/250 lub PW 2/1000	PZ 2/250 lub PW 2/1000	PZ 2/250 lub PW 2/1000	PZ 2/250 lub PW 2/1000	PZ 2/250 lub PW 2/1000
Wyładunek										
Otwieranie/ Zamykanie pokryw										
Wymagane ciśnienie [bar]	6	6	6	6	6	6	6	6	6	6

MODEL MASZYNY [MIX]	500 S	750 S	1000 S	1250 S	1600 S	2100 S	2600 S	3200 S	3800 S	4800 S
	500 SV	750 SV	1000 SV	1250 SV	1600 SV	2100 SV	2600 SV	3200 SV	3800 SV	4800 SV
Podajnik załadunkowy	<input type="checkbox"/>	<input type="checkbox"/>	<input type="checkbox"/>	<input type="checkbox"/>	<input type="checkbox"/>	<input type="checkbox"/>	<input type="checkbox"/>	<input type="checkbox"/>	<input type="checkbox"/>	<input type="checkbox"/>
PLC i HMI	<input type="checkbox"/>	<input type="checkbox"/>	<input type="checkbox"/>	<input type="checkbox"/>	<input type="checkbox"/>	<input type="checkbox"/>	<input type="checkbox"/>	<input type="checkbox"/>	<input type="checkbox"/>	<input type="checkbox"/>
Płynna regulacja obrotów	<input type="checkbox"/>	<input type="checkbox"/>	<input type="checkbox"/>	<input type="checkbox"/>	<input type="checkbox"/>	<input type="checkbox"/>	<input type="checkbox"/>	<input type="checkbox"/>	<input type="checkbox"/>	<input type="checkbox"/>
	<input type="checkbox"/>	<input type="checkbox"/>	<input type="checkbox"/>	<input type="checkbox"/>	<input type="checkbox"/>	<input type="checkbox"/>	<input type="checkbox"/>	<input type="checkbox"/>	<input type="checkbox"/>	<input type="checkbox"/>
Pomiar temperatury farszu	<input type="checkbox"/>	<input type="checkbox"/>	<input type="checkbox"/>	<input type="checkbox"/>	<input type="checkbox"/>	<input type="checkbox"/>	<input type="checkbox"/>	<input type="checkbox"/>	<input type="checkbox"/>	<input type="checkbox"/>
Automatyczne dozowanie wody	<input type="checkbox"/>	<input type="checkbox"/>	<input type="checkbox"/>	<input type="checkbox"/>	<input type="checkbox"/>	<input type="checkbox"/>	<input type="checkbox"/>	<input type="checkbox"/>	<input type="checkbox"/>	<input type="checkbox"/>
System wagowy	<input type="checkbox"/>	<input type="checkbox"/>	<input type="checkbox"/>	<input type="checkbox"/>	<input type="checkbox"/>	<input type="checkbox"/>	<input type="checkbox"/>	<input type="checkbox"/>	<input type="checkbox"/>	<input type="checkbox"/>
System uszczelnień "Easy Clean"	<input type="checkbox"/>	<input type="checkbox"/>	<input type="checkbox"/>	<input type="checkbox"/>	<input type="checkbox"/>	<input type="checkbox"/>	<input type="checkbox"/>	<input type="checkbox"/>	<input type="checkbox"/>	<input type="checkbox"/>
Dodatkowa ażurowa osłona górna	<input type="checkbox"/>	<input type="checkbox"/>	<input type="checkbox"/>	<input type="checkbox"/>	<input type="checkbox"/>	<input type="checkbox"/>	<input type="checkbox"/>	<input type="checkbox"/>	<input type="checkbox"/>	<input type="checkbox"/>
	<input type="checkbox"/>	<input type="checkbox"/>	<input type="checkbox"/>	<input type="checkbox"/>	<input type="checkbox"/>	<input type="checkbox"/>	<input type="checkbox"/>	<input type="checkbox"/>	<input type="checkbox"/>	<input type="checkbox"/>
Szlifowana wanna i wały	<input type="checkbox"/>	<input type="checkbox"/>	<input type="checkbox"/>	<input type="checkbox"/>	<input type="checkbox"/>	<input type="checkbox"/>	<input type="checkbox"/>	<input type="checkbox"/>	<input type="checkbox"/>	<input type="checkbox"/>
Podwójny płaszcz max ciśnienie 2.0 Bar	<input type="checkbox"/>	<input type="checkbox"/>	<input type="checkbox"/>	<input type="checkbox"/>	<input type="checkbox"/>	<input type="checkbox"/>	<input type="checkbox"/>	<input type="checkbox"/>	<input type="checkbox"/>	<input type="checkbox"/>
Pełna, szczelna pokrywa	<input type="checkbox"/>	<input type="checkbox"/>	<input type="checkbox"/>	<input type="checkbox"/>	<input type="checkbox"/>	<input type="checkbox"/>	<input type="checkbox"/>	<input type="checkbox"/>	<input type="checkbox"/>	<input type="checkbox"/>
	<input type="checkbox"/>	<input type="checkbox"/>	<input type="checkbox"/>	<input type="checkbox"/>	<input type="checkbox"/>	<input type="checkbox"/>	<input type="checkbox"/>	<input type="checkbox"/>	<input type="checkbox"/>	<input type="checkbox"/>

SPECYFIKACJA URZĄDZEŃ SERII MIX S & MIX SV

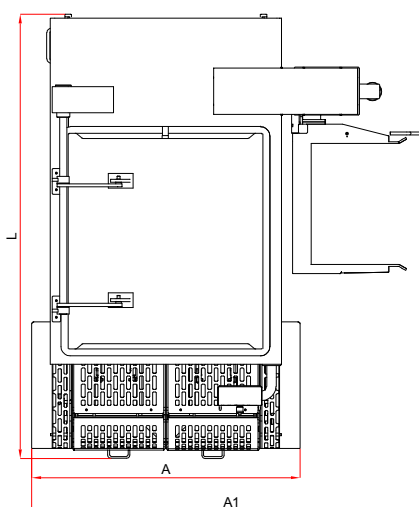
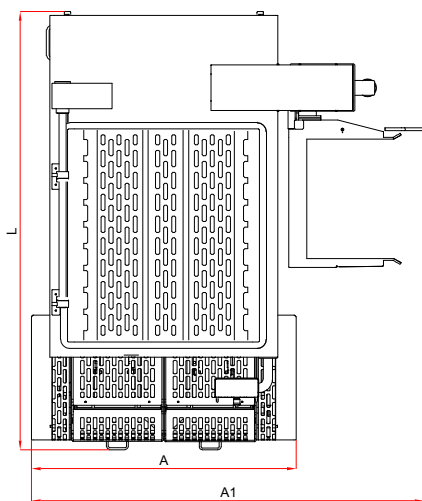
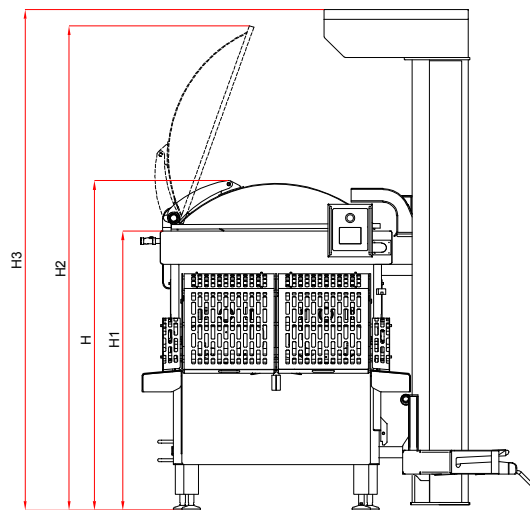
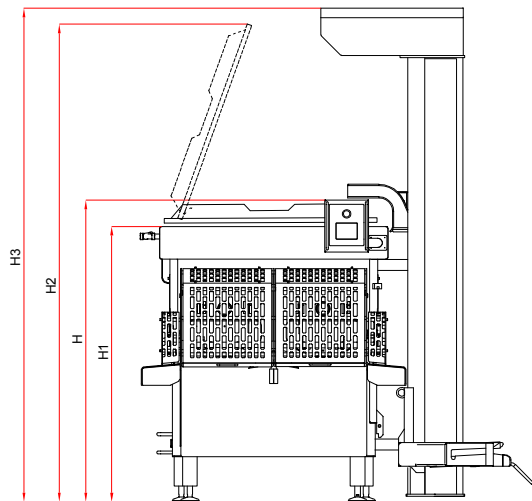

MIX S

MIX SV

MODEL MASZYNY [MIX]	500 S	750 S	1000 S	1250 S	1600 S	2100 S	2600 S	3200 S	3800 S	4800 S
	500 SV	750 SV	1000 SV	1250 SV	1600 SV	2100 SV	2600 SV	3200 SV	3800 SV	4800 SV
H [cm]	160	163	164	168	191	202	216	233	270	289
H1 [cm]	149	152	153	155	167	174	185	217	240	260
H2 [cm]	245	265	268	289	310	339	349	361	390	428
H3 [cm]	251	271	271	282	300	300	325	358	358	406
L [cm]	200	229	225	243	340	371	373	391	405	436
A [cm]	120	132	145	156	166	182	195	216	221	232
A1 [cm]	190	202	215	226	236	252	365	380	385	395